



INSTALLATION INSTRUCTIONS



TOYOTA GR COROLLA 1.6L

PART NO. 19631

BILL OF MATERIALS:

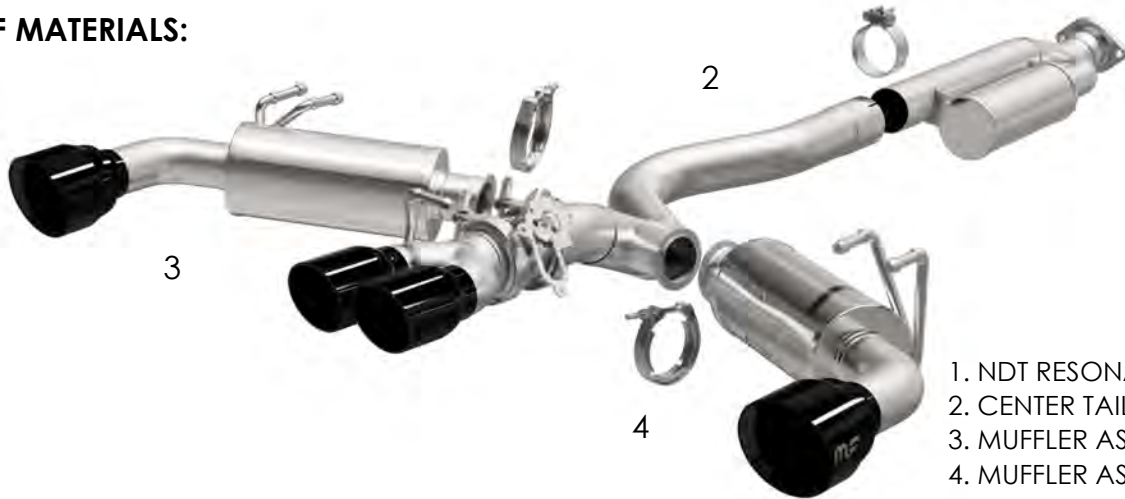

- 1. NDT RESONATOR ASSY
- 2. CENTER TAILPIPE ASSY
- 3. MUFFLER ASSY D/S
- 4. MUFFLER ASSY P/S

SHOP SUPPLIES:

HARDWARE KIT:



WEAR SAFETY GLASSES



READ INSTRUCTIONS THOROUGHLY BEFORE INSTALLING PRODUCT



SPRAY LUBRICANT

To ease removal of existing exhaust components (especially on older vehicles) spray penetrating lubricant on all fasteners and hangers/insulators that will be loosened or removed and let soak before disassembly.

- 1. [1] 3.00 Torca Clamp
- 2. [2] 2.50 Band Clamp
- 3. [3] 1/4-20x1.00 Hex Bolt
- 4. [3] 1/4" Split Washer
- 5. [3] 1/4-20 Hex Nut

MINIMUM REQUIRED TOOLS:



13mm



Hanger Tool (Or Pry Bar)

MAGNAFLOW RECOMMENDS PROFESSIONAL INSTALLATION ON ALL THEIR PRODUCTS



WARNING: When working on, under, or around any vehicle exercise caution. Please allow the vehicle's exhaust system to cool before removal, as exhaust system temperatures may cause severe burns. If working without a lift always consult vehicle manual for correct lifting specifications. Always wear safety glasses and ensure a safe work area. Serious injury or death could occur if safety measures are not followed.

ATTENTION: Always install any supplied band or U-bolt clamps to the proper torque specifications of 40-45 ft-lb for band clamps and 30-35 ft-lb for U-bolt clamps. Over tightening will result in the clamps breaking and will NOT be warranted by MagnaFlow.

MAGNAFLOW: 1901 Corporate Centre Dr - Oceanside, CA 92056 | 1(800)990-0905
Technical Support: 1(800) 959-9226 | Email: moreinfo@magnaflow.com

INSTALLATION INSTRUCTIONS

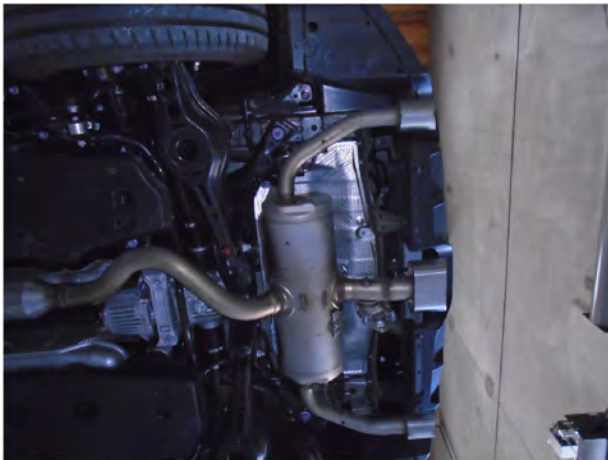

Step 1: To remove the OE exhaust begin by unplugging the valve motor at the center tailpipe then un-fasten the hardware at the flange. While supporting the exhaust extract the hangers from the rubber insulators (retain the fasteners and rubber insulators as they will be re-used).



ATTENTION

PLEASE REVIEW SHEET 4 OF THE INSTRUCTIONS BEFORE INSTALLING THE VALVE MOTOR.

Step 2: Once the system is on the ground you can transfer the valve motor from the OE system to the MagnaFlow system using the supplied fasteners.



Step 3: Begin Installing the new MagnaFlow system by attaching the NDT Resonator Assembly to the OE outlet using the OE fasteners and fitting the hanger into the rubber insulator.

MAGNAFLOW: 1901 Corporate Centre Dr - Oceanside, CA 92056 | 1(800)990-0905
Technical Support: 1(800) 959-9226 | Email: moreinfo@magnaflow.com

INSTALLATION INSTRUCTIONS

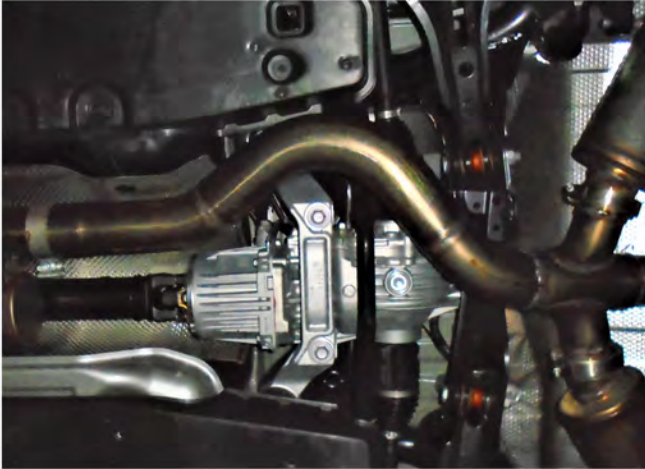

Step 4: Next, attach the Center Tailpipe Assembly to the Resonator using the supplied 3.00 Clamp. Keep this section supported until the installation is complete.

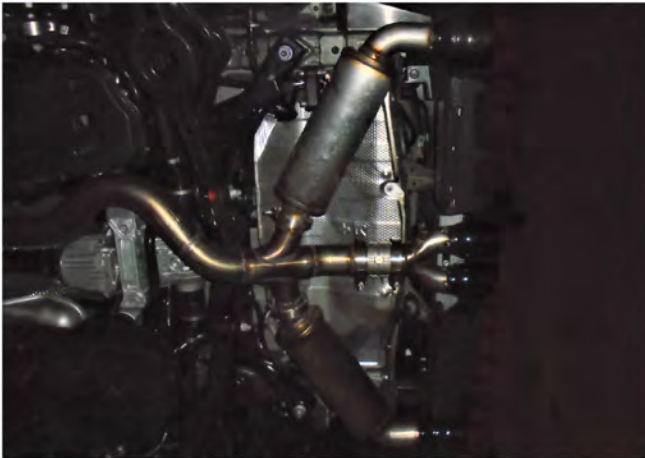

Step 5: Finish the installation by fitting the Driver and Passenger Side Muffler Assemblies onto the Center Tailpipe Assembly using the supplied Band Clamps and fitting the hangers into the rubber insulators. You can now plug the connector back into the valve motor.



Step 6: Once a final position has been chosen for the new exhaust system, evenly tighten all clamps from front to rear using the torque specifications on page one of the instructions. Inspect all fasteners after 25-50 miles of operation and re-tighten if necessary.

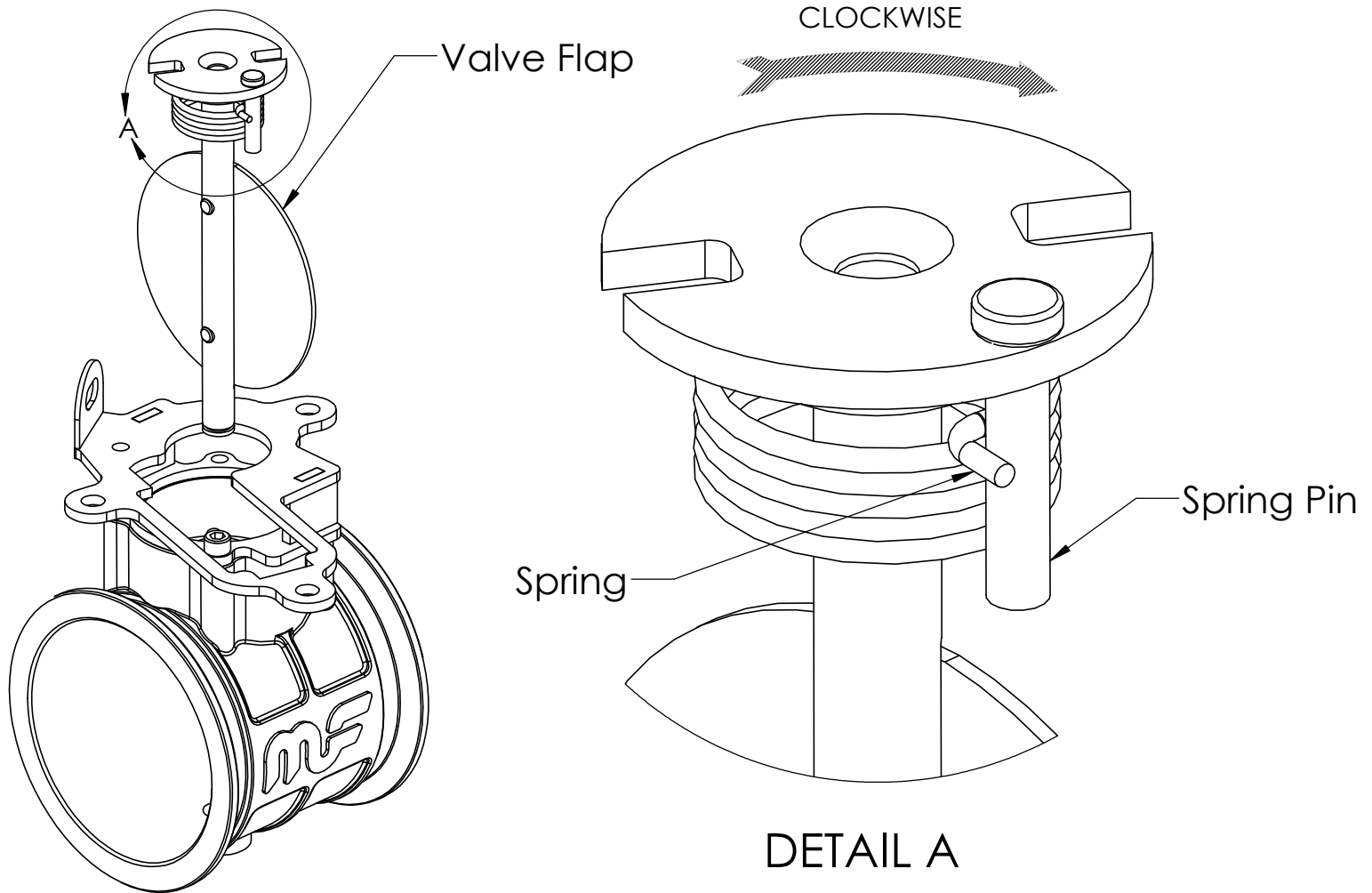

Before installing the OE Valve Motor to the MagnaFlow valve it is very important to have the valve flap oriented correctly.

When installing the valve motor rotate the valve flap clockwise so the Spring Pin is resting against the correct side of the Spring. In shipping the Valve Flap Assembly (Spring Pin) can move, and the motor can be installed with the Valve Flap 180° or 360° out of orientation. It is very important that the Spring Pin rest on the correct side of the Spring (*as shown in Detail A*) when the motor is installed.